

DESCRIPTION

The next generation E-Series G2® Ultrasonic meter uses solid-state technology in a compact, tamper protected, weatherproof and UV-resistant housing, suitable for commercial applications. Electronic metering provides information—such as rate of flow and status and alarm indication—and data not typically available through traditional, mechanical meters and registers. Electronic metering minimizes measurement errors due to sand, suspended particles and pressure fluctuations.

Ultrasonic 3, 4, 6 and 8 inch Meter Features

- Open flow tube design prevents flow obstruction to reduce pressure loss
- Greater turn-down ratio for extended flow ranges and increased revenue
- Easy-to-read, 9-digit LCD display, which presents consumption, rate of flow, unit of measure, pressure, temperature, alarm conditions and firmware version
- Pressure alarm and pressure and temperature data reported through ORION Cellular LTE-M/LTE endpoints and BEACON®
- Field programmable registration and maintains an hourly internal logging capacity of 160 days of data
- Single and dual outputs include high resolution industry standard ASCII encoder protocol, scaled/unscaled and 4-20 mA

The meter is available with an inline connector for easy connection and installation to ORION endpoints. It is also available with a flying lead for field splice connection.

APPLICATIONS

Use the E-Series Ultrasonic meter for measuring potable cold water in commercial and industrial services. The meter is also ideal for non-potable, reclaimed irrigation water applications or less than optimum water conditions where small particles exist.

E-Series Ultrasonic meters meet and exceed AWWA C715 and the most recent revision of AWWA C750 Standards. The lead-free bronze alloy meters comply with the lead-free provisions of the Safe Drinking Water Act and NSF/ANSI/CAN Standards 61 and 372. E-Series Ultrasonic meters also conform to UL 327B and FM 1044 for fire service applications.

OPERATION & PERFORMANCE

As water flows into the measuring tube, ultrasonic signals are sent consecutively in forward and reverse directions of flow. Velocity is then determined by measuring the time difference between the measurement in the forward and reverse directions. Total volume is calculated from the measured flow velocity using water temperature and pipe diameter. The LCD shows total volume, unit of measure, rate of flow, pressure, temperature, firmware and

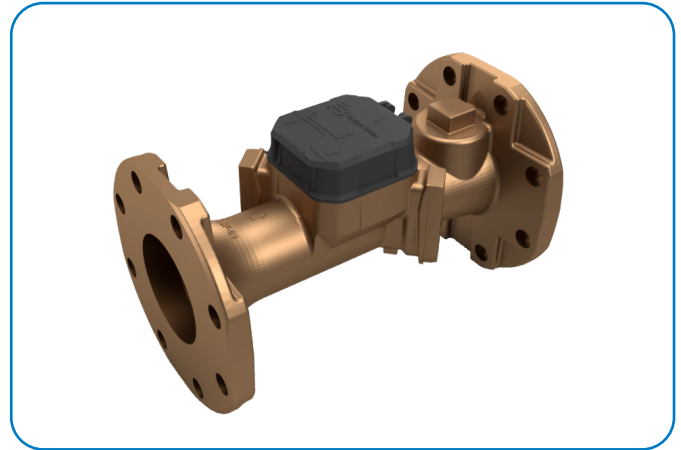

alarm conditions (reverse-flow, no usage, empty pipe, exceeding max flow, suspected leak, pressure, temperature, end of life and measurement error).

In normal temperature range of 45...122° F (7...50° C), the Ultrasonic “new meter” consumption measurement is accurate to:

- ±1.5% over the normal flow range
- ±3.0% from the extended low flow range to the minimum flow value

CONSTRUCTION

The E-Series Ultrasonic meter features lead-free bronze alloy meter housing, ultrasonic transducers, a meter-control circuit board with associated wiring, LCD and battery. Wetted elements are limited to the pressure vessel and transducers. The electronic components are housed and fully potted within a molded, engineered polymer enclosure, which is attached to the meter housing. The transducers extend through the housing and are sealed by O-rings, enabling turbulence-free water flow through the tube. The open flow tube design prevents obstruction of flow to reduce pressure loss and provide long-term accuracy.

METER INSTALLATION

For long-term performance the meter is weatherproof, UV-resistant, fully submersible and can be installed using horizontal or vertical piping. The registration electronics and battery are encapsulated to withstand harsh environments and protect the electronics in flooded or submerged pit applications. The meter will not measure flow when an “empty pipe” condition is experienced. An empty pipe is defined as a condition that occurs when the flow sensors are not fully submerged.



SPECIFICATIONS

E-Series G2 Ultrasonic Meter Size	3 in.		4 in.		6 in.		8 in.
	3 × 12 in. (76 × 305 mm)	3 × 17 in. (76 × 432 mm)	4 × 14 in. (102 × 356 mm)	4 × 20 in. (102 × 508 mm)	6 × 18 in. (152 × 457 mm)	6 × 24 in. (152 × 610 mm)	8 × 20 in. (203 × 508 mm)
Normal Test Flow Limits	0.75...560 gpm		1.5...1100 gpm		2.2...2000 gpm		4...3500 gpm
Minimum Test Flow Limits	0.37 gpm		0.75 gpm		1.1 gpm		2.0 gpm
Safe Maximum Operating Condition (SMOC)	560 gpm		1100 gpm		2000 gpm		3500 gpm
Typical Pressure Loss	2.6 psi @ 350 gpm		2.1 psi @ 630 gpm		1.5 psi @ 1400 gpm	1.8 psi @ 1400 gpm	2.4 psi @ 2800 gpm
Totalization Display Resolution	3 inch and 4 inch meters				6 inch and 8 inch meters		
	<ul style="list-style-type: none"> Gallons: 0.1 Cubic feet: 0.01 Cubic meters: 0.001 				<ul style="list-style-type: none"> Gallons: 1.0 Cubic feet: 0.1 Cubic meters: 0.01 		
Operating Performance	In normal temperature range of 45...122° F (7...50° C), new meter consumption measurement is accurate to: <ul style="list-style-type: none"> 100% ±1.5% over the normal test flow limits 100% ±3.0% for the minimum test flow limits 						
Storage Temperature	- 40...140° F (- 40...60° C)						
Maximum Ambient Storage (Storage for One Hour)	150° F (66° C)						
Measured Fluid Temperature Range	34...140° F (1...60° C) .						
Humidity	0...100% condensing; meter is capable of operating in fully submerged environments						
Maximum Working Pressure of Meter Housing	175 psi (12 bar)						
Maximum Operating Pressure of Pressure Sensor	150 psi (10 bar)						
Pressure Sensor Accuracy	±2% of full scale pressure, up to 150 psi (10 bar)						
Register Type	Straight reading, permanently sealed electronic LCD; digits are 0.28 in. (7 mm) high						
Register Display	<ul style="list-style-type: none"> Consumption (up to nine digits) Rate of flow Alarms Pressure 				<ul style="list-style-type: none"> Temperature Firmware version Unit of measure factory programmed for gallons, cubic feet and cubic meters 		
Scaled/Unscaled Output*	Solid-state relay with 4-20mA output; open drain MOSFET with encoder output						
Max. Voltage	30V DC						
Current	100 mA						
Pulse Width	50 ms (programmable 30...100 ms)						
Analog 4-20 mA Output*	Two-wire/passive						
Input Voltage Range	9...50V DC supply						
Current	4...20 mA						
Max. Load Resistance (Ohms)	50 Ohms + 50 Ohms (supply voltage - 9V)						
Battery	3.6-volt lithium thionyl chloride battery is fully encapsulated within the register housing and is not replaceable. 20-year battery life; 15-year battery life for scaled/unscaled dual output meters						

NOTE: See Pressure Loss Chart on [page 4](#) for typical pressure loss over complete UL 327B flow range.

* Applicable to meters with dual output options

PHYSICAL DIMENSIONS

E-Series G2 Ultrasonic Meter Size	3 in.		4 in.		6 in.		8 in.
	Round	Round	Round	Round	Round	Round	Round
Size Designation X Lay Length	3 × 12 in. (76 × 305 mm)	3 × 17 in. (76 × 432 mm)	4 × 14 in. (102 × 356 mm)	4 × 20 in. (102 × 508 mm)	6 × 18 in. (152 × 457 mm)	6 × 24 in. (152 × 610 mm)	8 × 20 in. (203 × 508 mm)
Weight (without AMR)	26 lb (11.8 kg)	28.5 lb (12.9 kg)	38 lb (17.2 kg)	42 lb (19.1 kg)	59 lb (26.8 kg)	66 lb (29.9 kg)	96 lb (43.5 kg)
See illustration below for Measurement Designations							
Length (A)	12 in. (305 mm)	17 in. (432 mm)	14 in. (356 mm)	20 in. (508 mm)	18 in. (457 mm)	24 in. (610 mm)	20 in. (508 mm)
Height (B)	3.76 in. (95 mm)	3.76 in. (95 mm)	3.99 in. (101 mm)	3.99 in. (101 mm)	5.15 in. (131 mm)	5.15 in. (131 mm)	6.49 in. (165 mm)
Height (C)	7.08 in. (180 mm)	7.08 in. (180 mm)	8.5 in. (216 mm)	8.5 in. (216 mm)	10.36 in. (263 mm)	10.36 in. (263 mm)	13.05 in. (331 mm)
Height with Lifting Ring	NA	NA	NA	NA	12.96 in. (329 mm)	12.96 in. (329 mm)	15.65 in. (398 mm)
Length (D)	6 in. (152 mm)	8.5 in. (216 mm)	7 in. (178 mm)	10 in. (254 mm)	8 in. (203 mm)	8 in. (203 mm)	9 in. (229 mm)
Width (E)	7.5 in. (191 mm)	7.5 in. (191 mm)	9 in. (229 mm)	9 in. (229 mm)	11 in. (279 mm)	11 in. (279 mm)	13.50 in. (343 mm)
Number of Bolts	4	4	8	8	8	8	8
Bolt Hole Diameter	0.781 in. (19.84 mm)						
Companion Flange	3 in. (76 mm)	3 in. (76 mm)	4 in. (102 mm)	4 in. (102 mm)	6 in. (152 mm)	6 in. (152 mm)	8 in. (203 mm)
NPT Test Port	1.5 in. (38 mm)	1.5 in. (38 mm)	2 in. (51 mm)	2 in. (51 mm)	2 in. (51 mm)	2 in. (51 mm)	2 in. (51 mm)

Measurement Designations

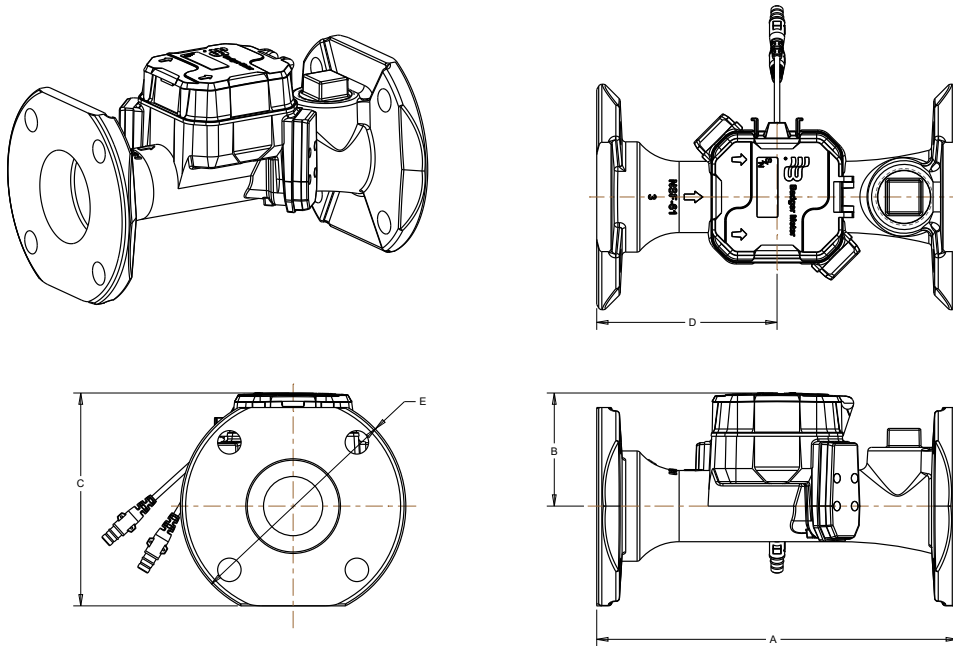

Drawings illustrate the 3 inch meter

MATERIALS

Meter Housing	Lead-free bronze alloy
Measuring Section	Ultrasonic sensors located in the flow tube
Register Housing & Lid	Engineered polymer
Transducer Port Covers 3 in., 4 in.	Lead-free bronze alloy
Transducer Port Covers 6 in., 8 in.	Engineered polymer

PRESSURE LOSS CHARTS

Charts represent typical meter performance. Rate of flow in gallons per minute (gpm).

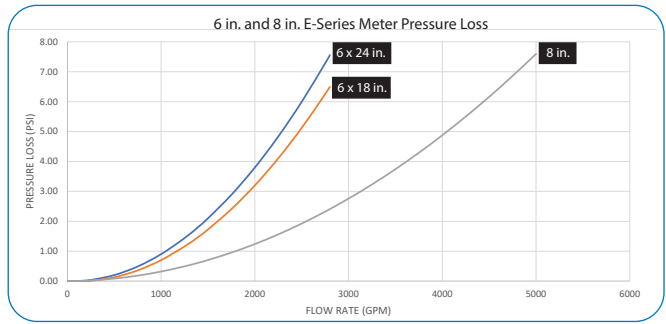
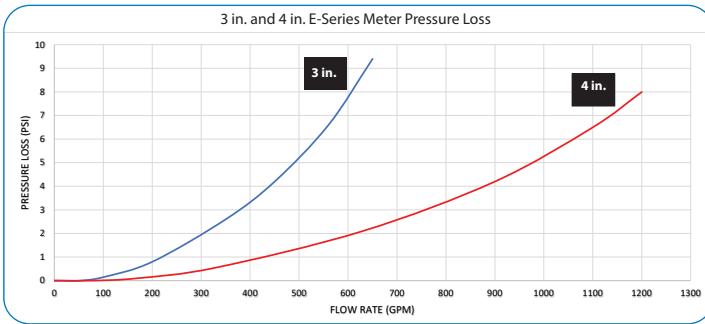

ACCURACY CHARTS

Charts represent typical meter performance. Rate of flow in gallons per minute (gpm).

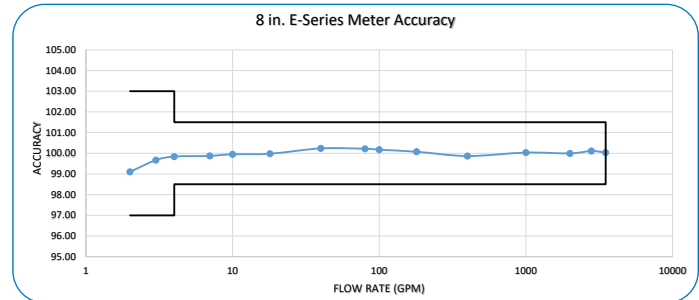
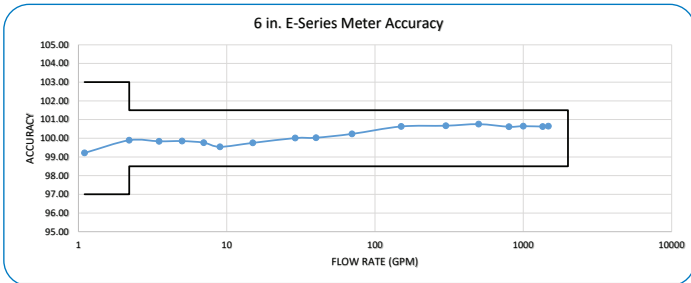
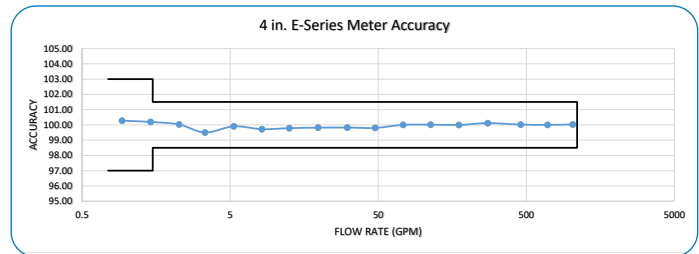
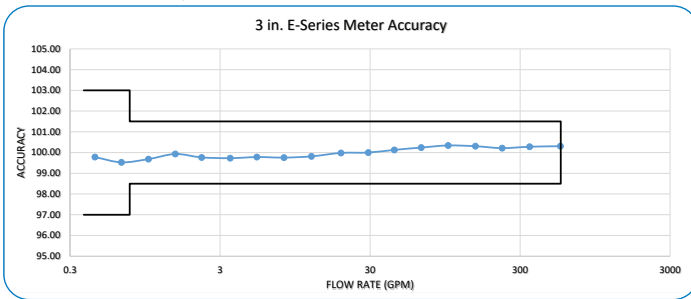

SMART WATER IS BADGER METER

BEACON, E-Series, E-Series G2 and ORION are registered trademarks of Badger Meter, Inc. Other trademarks appearing in this document are the property of their respective entities. Due to continuous research, product improvements and enhancements, Badger Meter reserves the right to change product or system specifications without notice, except to the extent an outstanding contractual obligation exists. © 2023 Badger Meter, Inc. All rights reserved.